



DIELECTRIC RESONATOR OSCILLATOR (DRO-1000)

DRO-1000

FEATURES

- * DIELECTRIC RESONATOR
- * INTERNAL VOLTAGE REGULATOR
- * 150 MHz BANDWIDTH
- * LOW PHASE NOISE
- * MIC FABRICATION
- * LOW MICROPHONICS
- * LOW POWER CONSUMPTION
- * UP TO +25 dBm OUTPUT POWER
- * AVAILABLE FROM 1-50 GHz
- * OPERATING RANGE: -55°C TO +105°C

APPLICATION

- * SATELLITE COMMUNICATIONS
- * CABLE TV LINKS (CATV)
- * LOCAL AREA NETWORKS (LAN)
- * GLOBAL POSITIONING SYSTEMS (GPS)
- * TEST EQUIPMENT
- * POINT TO POINT
- * UP/DOWN CONVERTERS
- * TRANSMITTER & RECEIVERS
- * DIGITAL RADIOS
- * MISSILE GUIDANCE
- * SPACE, MILITARY, COMMERCIAL

DESCRIPTION

DRO-1000 Series Dielectric Resonator Oscillator (DRO) utilizes state of the art MIC to provide highly stable, reliable and efficient signal source at microwave frequencies up to 50 GHz. The low profile and rugged construction provide excellent durability against harsh environmental conditions.

DRO-1000 oscillator is designed using FET or BJT amplifier with series feed back at source and Dielectric Resonator at the gate. High gain, low-noise FETs/BJTs are biased positively or negatively at the gate to ensure minimum phase-noise. The device is carefully matched for maximum power, minimum phase-noise and Voltage Standing Wave Ratio (VSWR). The oscillator is matched for maximum temperature stability and optimum negative resistance.

DRO-1000 oscillator is buffered by cascaded low-noise driver and power amplifiers for minimum load pulling, maximum isolation and power. FET/BJT devices are directly attached to gold plated Kovar carriers to minimize shear effect and maximize heat sinking. Kovar carriers are mounted to the chassis to provide an efficient thermal junction and a stable structure for reduction of microphonics. To ensure oscillator stability over the full temperature range, the tuning elements are precisely designed and positioned to compensate for temperature drift by a factor of three.

DRO-1000 series provides several advantages over other microwave signal sources, such as Gunn Cavity Oscillators and Crystal Multiplier Chains.

DRO-1000 series is internally voltage regulated to avoid reverse bias, frequency pushing, bias modulation and voltage transients. Mechanical frequency adjustment is provided for optimum phase voltage setting.

SPECIFICATION

Model Number	DRO-1000-XX.XX (Where XX.XX is freq in GHz)
Single Frequency	1.00 to 50.00 GHz
Mechanical Tuning Range	100 MHz
Electrical Tuning	Optional
Power Output	+13 dBm, up to + 25 dBm Optional
Load VSWR, Maximum	2.0: 1.0
Power Requirements	+15, +12, +10 VDC, 90 mA
Pushing / Pulling	10 ppm/V Max / +/- 90 ppm Max
Frequency Stability	4 ppm / °C
Phase Noise	See Phase Noise Envelope (Fig. A)
Spurious	-85 dBc
Harmonics	-25 dBc
Operating Temperature	0°C to 50°C Standard; -55°C to 105°C Optional
Storage Temperature	-55°C to 125°C
Connectors	SMA-Female or 2.92 mm-Female
Size	2.25" x .93" .67"
Finish	Nickel

PHASE NOISE ENVELOPE

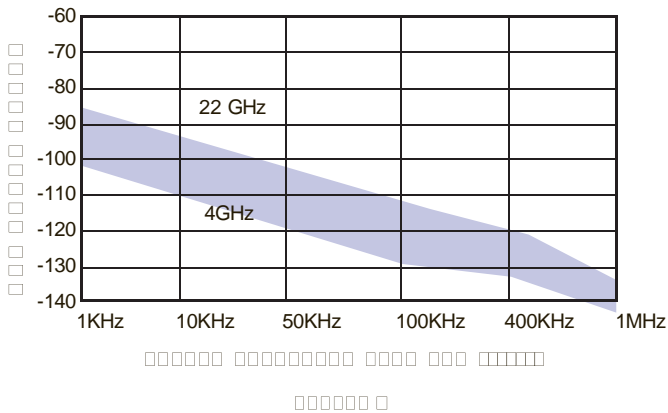

BLOCK DIAGRAM

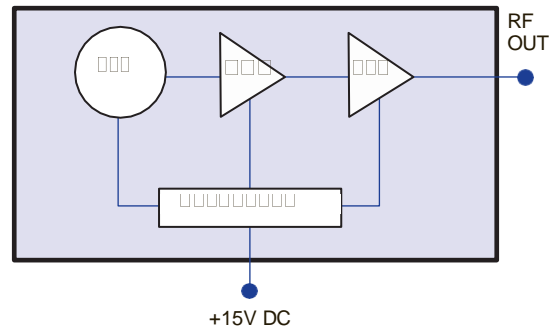

OUTLINE DRAWING

