

MINI-DRO

1.2" x 1.2" x .660" PACKAGE



SPECIFICATIONS:

Model Number	DRO-1500-XX.XX (Where XX.XX is freq. in GHz)
Single Frequency	2.00 to 40.00 GHz
Mechanical Tuning Range	50 MHz
Electrical Tuning	Not Available
Power Output	+13 dBm, up to +20 dBm Optional
Load VSWR, Maximum	2.0 :1.0
Power Requirements	+15, +12, +8VDC @90mA, max
Power Variation	+/-0.5dBm
Pushing	10ppm/V Max.
Pulling (12 dB Return Loss)	+/- 90 ppm Max.
Frequency Stability	4 ppm / °C
Phase Noise	See Phase Noise Envelope (Fig.A)
Spurious	-85 dBc
Harmonics	-25 dBc
Operating Temperature	0° to 50° Standard; -55° to +105°C Optional
Storage Temperature	-55° to +125°C
Connectors	SMA Female
Size	1.2" x 1.2" x .660"
Finish	Nickel

PHASE NOISE ENVELOPE

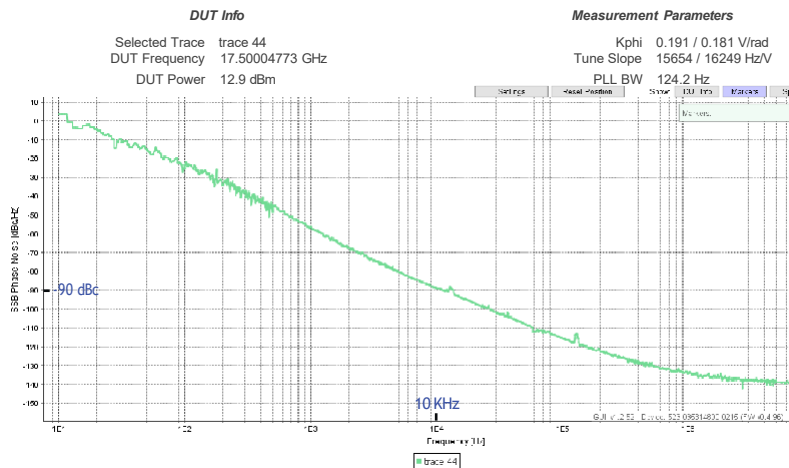

BLOCK DIAGRAM

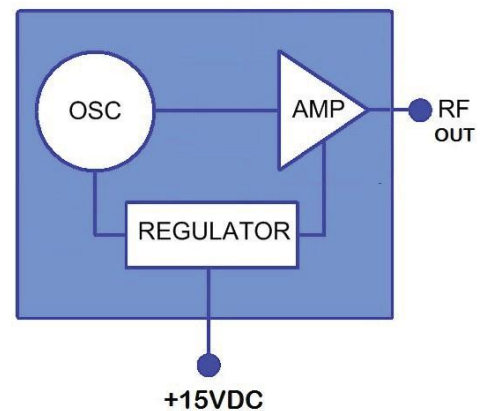

OUTLINE DRAWING

