

PLO-2000

External Ref 100 MHz PLDRO (PLO-2000)

FEATURES

- * DIELECTRIC RESONATOR
- * INTERNAL VOLTAGE REGULATOR
- * PHASE LOCK INDICATOR ALARM
- * LOW PHASE NOISE
- * MIC AND SMT FABRICATION
- * LOW MICROPHONICS
- * LOW POWER CONSUMPTION
- * UP TO +25 dBm OUTPUT POWER
- * AVAILABLE FROM 1-50 GHz
- * OPERATING RANGE: -55°C TO +105°C

APPLICATION

- * SATELLITE COMMUNICATIONS
- * CABLE TV LINKS (CATV)
- * LOCAL AREA NETWORKS (LAN)
- * GLOBAL POSITIONING SYSTEMS (GPS)
- * TEST EQUIPMENT
- * POINT TO POINT
- * UP/DOWN CONVERTERS
- * TRANSMITTER & RECEIVERS
- * DIGITAL RADIOS
- * MISSILE GUIDANCE
- * SPACE, MILITARY, COMMERCIAL

DESCRIPTION

PLO-2000 Series Phase Locked Dielectric Resonator Oscillator (PLDRO) utilizes state of the art MIC to provide highly stable, reliable and efficient signal source at microwave frequencies up to 50 GHz. The low profile and rugged construction provide excellent durability against harsh environmental conditions.

PLO-2000 oscillator is designed using FET or BJT amplifier with series feedback at source and Dielectric Resonator at the gate. High gain, low-noise FETs/BJTs are biased positively or negatively at the gate to ensure minimum phase-noise. The device is carefully matched for maximum power, minimum phase-noise and Voltage Standing Wave Ratio (VSWR). The oscillator is matched for maximum temperature stability and optimum negative resistance.

PLO-2000 oscillator is buffered by cascaded low-noise driver and power amplifiers for minimum load pulling, maximum isolation and power. FET/BJT devices are directly attached to gold plated Kovar carriers to minimize shear effect and maximize heat sinking. Kovar carriers are mounted to the chassis to provide an efficient thermal junction and a stable structure for reduction of microphonics. To ensure oscillator stability over the full temperature range, the tuning elements are precisely designed and positioned to compensate for temperature drift by a factor of three.

PLO-2000 series proprietary phase lock loop circuitry is surface mounted on thick film Alumina substrate. The reference frequency is multiplied and sampled to output frequency. Produced error voltage due to frequency drift is sensed by a Wein-Bridge Oscillator to provide the necessary sweep voltage to an ultra H-Q tuning varactor diode for the purpose of compensation and phase locking. The unique construction of phase lock loop sub-assembly provides excellent temperature stability and minimum solder joints for maximum reliability.

PLO-2000 series is internally voltage regulated to avoid reverse bias, frequency pushing, bias modulation and voltage transients. A phase lock indicator alarm of open TTL type is provided as a feature. The PLO-2000 series are externally reference locked and factory tuned to specified frequency. Mechanical frequency adjustment is provided for optimum phase voltage setting.

SPECIFICATIONS

Model Number	PLO-2000-XX.XX (Where XX.XX is freq in GHz)
Single Frequency	1.00 to 50.00 GHz
Mechanical Tuning Range	100 MHz
Power Output	+13 dBm, up to + 25 dBm Optional
Load VSWR, Maximum	2.0: 1.0
Power Requirements	+12, +15 VDC, 220 mA
Reference Input Frequency	50 to 200 MHz
Reference Power Input (Range)	10 dBm (-6 to +10 dBm)
Frequency Stability	Same as Reference
Phase Noise	Reference Noise + 20 Log (N) +3dB
Spurious	-80 dBc
Harmonics	-25 dBc
Operating Temperature	0°C to 50°C Standard; -55°C to 105°C Optional
Storage Temperature	-55°C to 125°C
Connectors	SMA-Female or 2.92 mm-Female
Size	2.25" x 2.25" .67"
Finish	Nickel

PHASE NOISE ENVELOPE

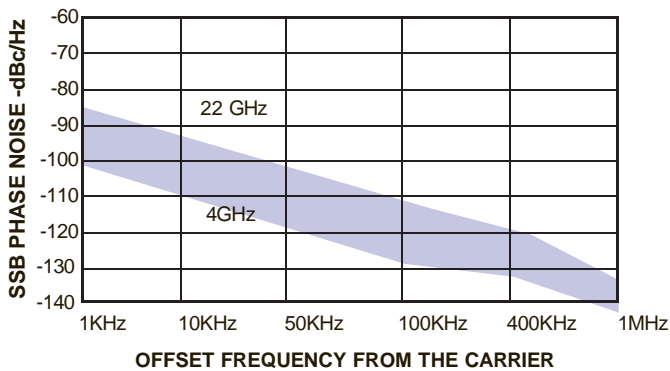
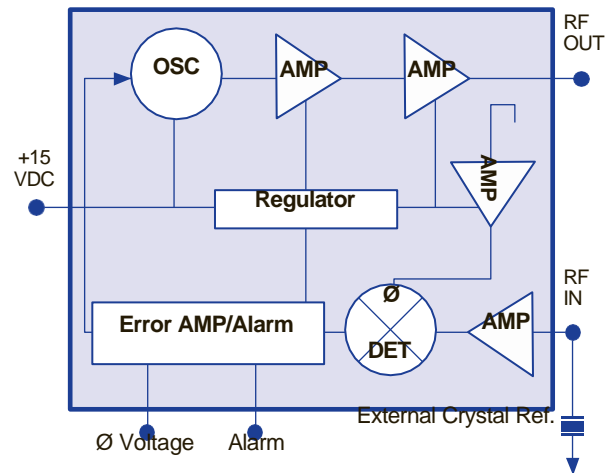
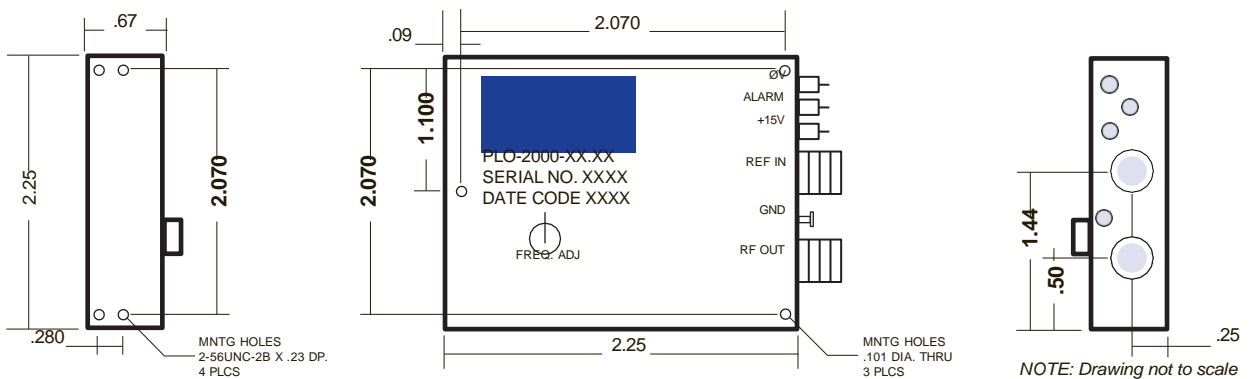

FIGURE A

BLOCK DIAGRAM



OUTLINE DRAWING



MICROWAVE DYNAMICS dba QUANTIC MWD, 16542 Scientific Way, Irvine, CA PHONE:949-679-7788 FAX: 949-679-7748

Web Page : <http://www.quantmwd.com>

Email: sales@quantmwd.com

COPYRIGHT © 2024 MICROWAVE DYNAMICS dba QUANTIC MWD, IRVINE CA • ORDERS ACCEPTED BY MICROWAVE DYNAMICS ARE SUBJECT TO OUR TERMS AND CONDITIONS OF SALE SPECIFICATIONS ARE SUBJECT TO CHANGE WITHOUT NOTICE